

EXHIBIT BOOTH DISPLAY GUIDELINES



The following exhibit booth display guidelines have been established to help SW Expo's exhibitors design their booths for SW Expo's events and to help maximize the exhibit experience for all exhibitors at each event. The guidelines will be strictly enforced by SW Fuel & Convenience Expo Show Management.

Exhibitors with variances to the display guidelines in this document must submit their design and request for approval in writing to SW Expo no later than 60 calendar days prior to the first day of the event. After review, SW Expo will provide written permission for reasonable variances.

Please review these display guidelines carefully. If on setup day of the show, SW Expo finds that a display does not meet the requirements of these guidelines, the exhibiting company may be asked to make adjustments accordingly and at cost to the exhibiting company.

These guidelines are by no means the only restrictions for the show. It is the exhibitor's responsibility to review the general contractor's Exhibitor Service Kit in its entirety to learn of all restrictions including union jurisdictions, electrical, rigging and shipping requirements. In addition to the guidelines in this document, all exhibitors are required to abide by the SW Expo Exhibit Space Rules & Regulations for the event(s) at which they are exhibiting.

SW Expo reserves the right to amend these guidelines at any time and provide appropriate notice of changes to exhibitors.

TABLE OF CONTENTS

PAGE 1

LINEAR BOOTHS

PAGE 2

CORNER BOOTHS

PAGE 3

PERIMETER BOOTHS

PAGE 4

END-CAP BOOTHS

PAGE 5

ISLAND BOOTHS

LINEAR BOOTHS

MAIN VIEW

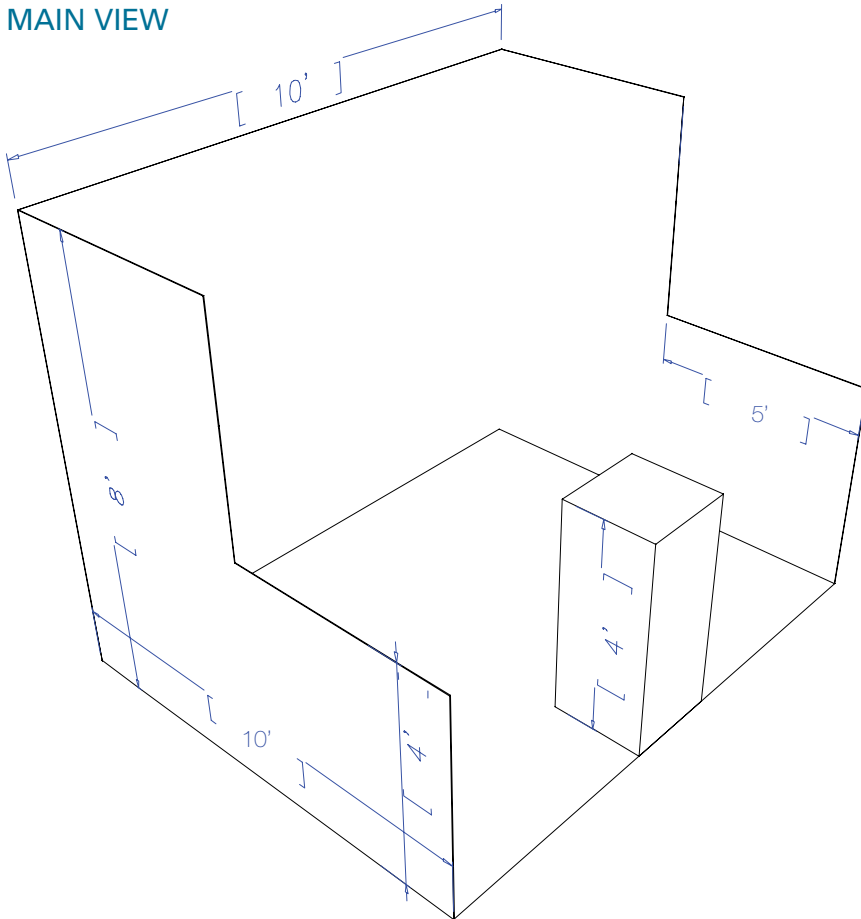

TOP VIEW

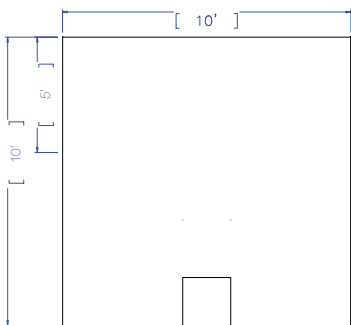

SIDE VIEW

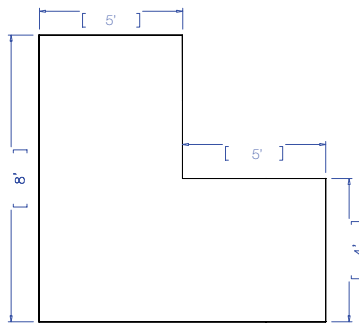

LINEAR BOOTHS

are the most common at SW Expo shows. They have one side (front side) exposed to the aisle and are lined up next to one another in a straight line. If you are in a linear booth, you will have other exhibiting companies on both sides of your booth. For SW Expo shows, linear booths have an 8-foot-high by 10-foot-wide draped back wall and a 3-foot-high by 8-foot-wide draped side divider on each side of the booth. Drape colors will vary from show to show. Different combinations of linear booths can be used to create island booths, split island booths and end-cap booths. See descriptions of these booth types for more details.

Use of Space in a Linear Booth

Regardless of the number of linear booths you are utilizing, the following restrictions apply to each individual booth.

The maximum height of the back 5 feet of the booth is 8 feet high. The maximum height of the front 5 feet of the booth is 4 feet high. All booth materials and displays must be contained within the lines of the booth. Hanging signs, graphics, canopies and other materials from the ceiling is not allowed for this booth type. Double booths with center extended headers must not exceed a maximum width of 4 feet for the extended header. If you are utilizing three or more linear booths in a row (total of 30 feet wide or more), the 4-foot-high limitation does not apply to the middle booth(s).

CORNER BOOTHS

MAIN VIEW

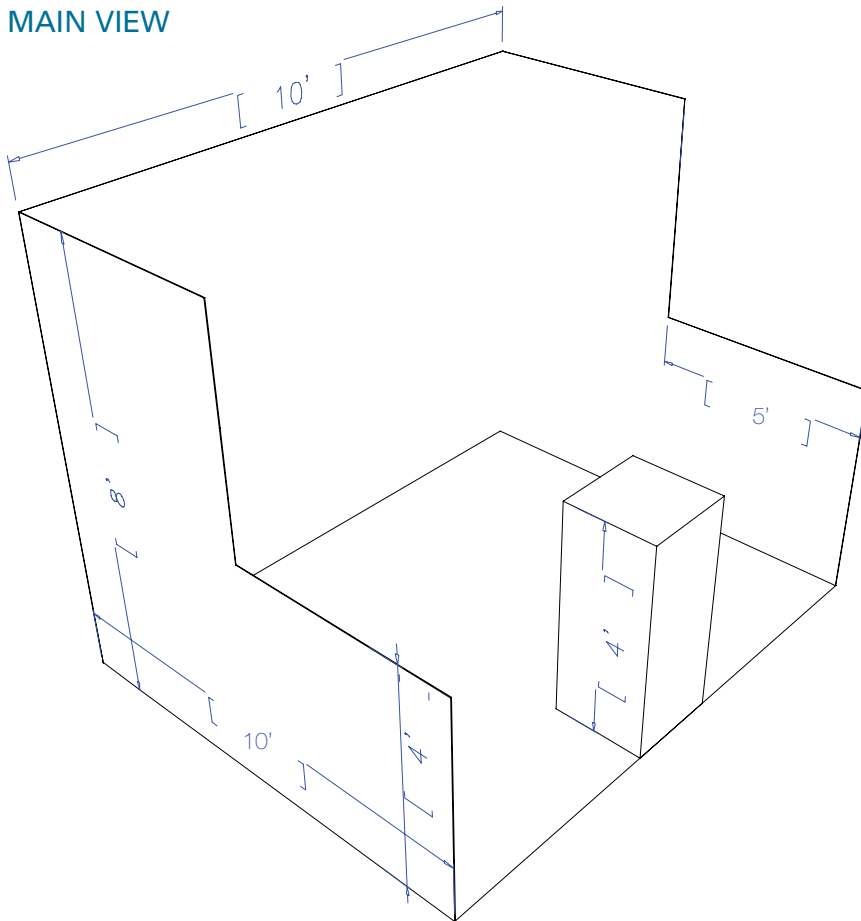

TOP VIEW

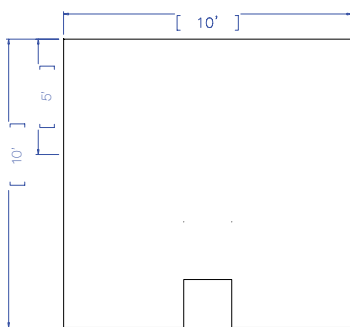

SIDE VIEW

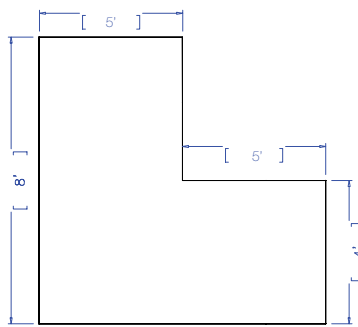

CORNER BOOTHS

are also common at SW Expo shows. They are linear booths that have two sides (front side and a right or left side) exposed to the intersecting aisles. If you are in a corner booth, you will have one other exhibiting company directly next to you. For SW Expo shows, corner booths have an 8-foot-high by 10-foot-wide draped back wall and a 3-foot-high by 8-foot-wide draped side divider on one side. Drape colors will vary from show to show. A combination of two corner booths at the end of a line of linear booths can be used to create an end-cap booth. See descriptions of end-cap booths for more details.

Use of Space in a Corner Booth

The following restrictions apply to corner booths and are the same as that of linear booths.

The maximum height of the back 5 feet of the booth is 8 feet high. The maximum height of the front 5 feet of the booth is 4 feet high. All booth materials and displays must be contained within the lines of the booth. Hanging signs, graphics, canopies and other materials from the ceiling is not allowed for this booth type. If you are utilizing three or more linear booths in a row including a corner booth (total of 30 feet wide or more), the 4-foot-high limitation does not apply to the middle booth(s).

PERIMETER BOOTHS

MAIN VIEW

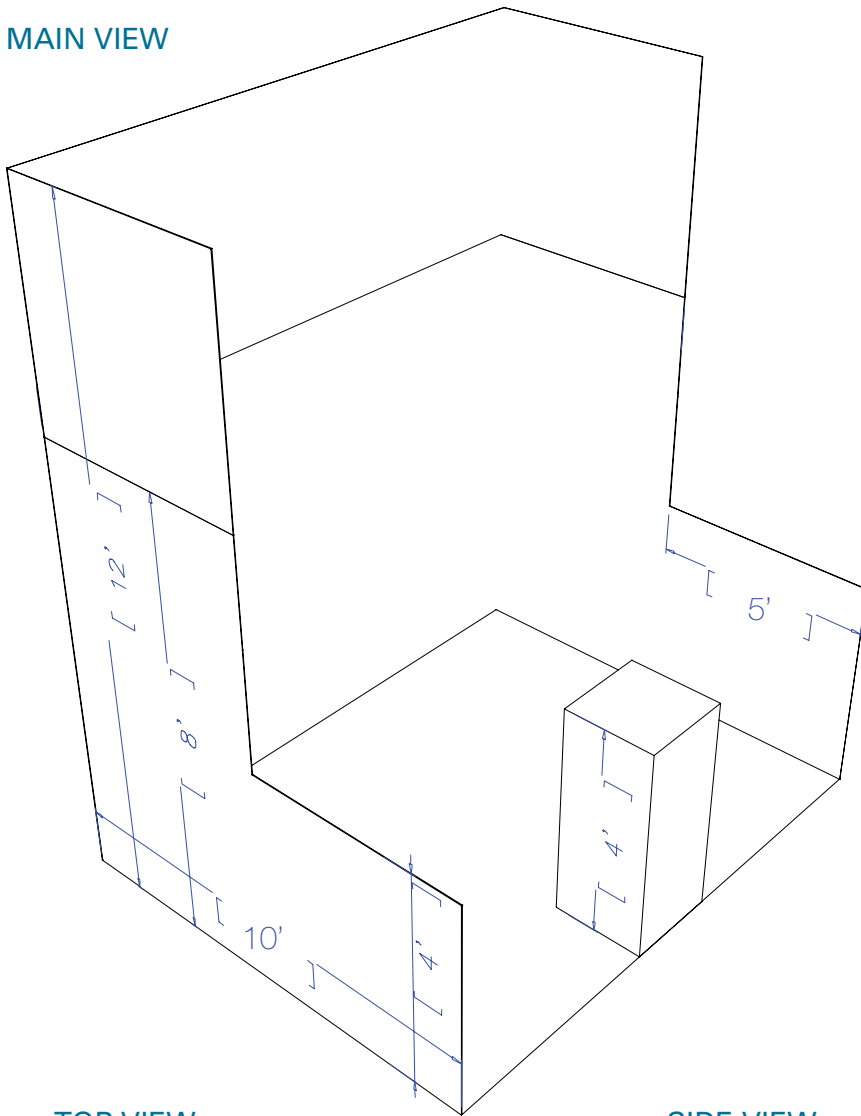

TOP VIEW

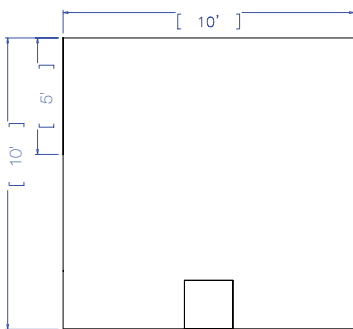

SIDE VIEW

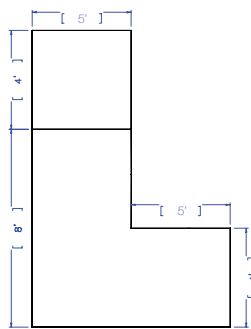

PERIMETER BOOTHS

are linear booths with one side (front side) exposed to the aisle. They are lined up next to one another in a straight line against a wall in the expo hall. In some instances, depending on layout of the floor plan, a perimeter booth could also be a booth that has its back to empty unused space in the expo hall. Check with SW Expo if you feel your booth may qualify as a perimeter booth. If you are in a perimeter booth, you will have at least one other exhibiting company next to your booth. For SW Expo shows, perimeter booths have an 8-foot-high by 10-foot-wide draped back wall and a 3-foot-high by 8-foot-wide draped side divider on each side of the booth. If you would like to have a 12-foot-high draped back wall, additional fees may apply. Drape colors will vary from show to show.

Use of Space in a Perimeter Booth

Regardless of the number of perimeter booths you are utilizing, the following restrictions apply to each individual booth.

The maximum height of the back 5 feet of the booth is 12 feet high. The maximum height of the front 5 feet of the booth is 4 feet high. All booth materials and displays must be contained within the lines of the booth. Hanging signs, graphics, canopies and other materials from the ceiling is not allowed for this booth type. If you are utilizing three or more perimeter booths in a row (total of 30 feet wide or more), the 4-foot-high limitation does not apply to the middle booth(s).

END-CAP BOOTHS

MAIN VIEW

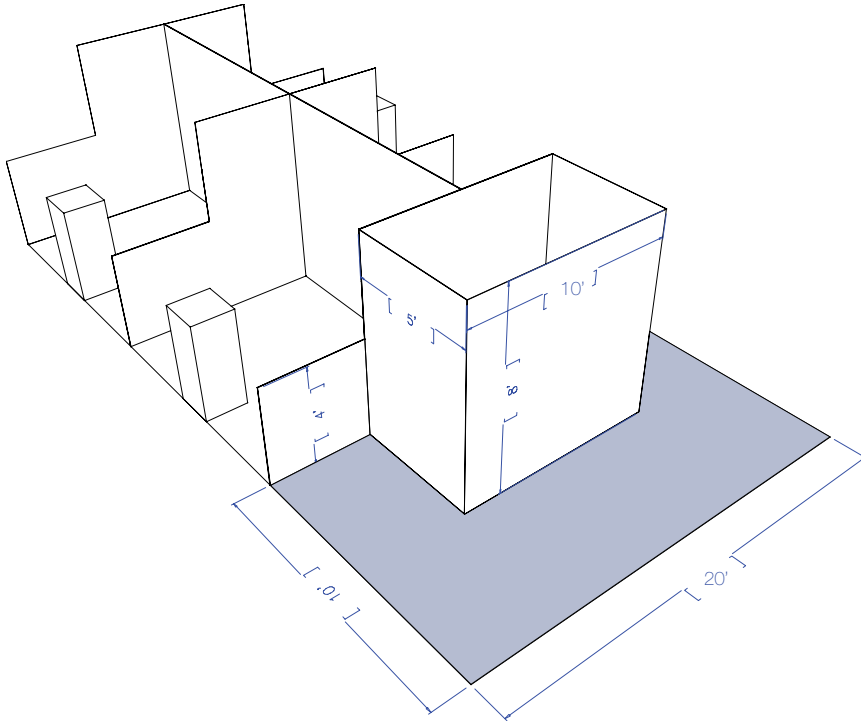

END-CAP BOOTHS

are two corner booths combined to create a 20-foot-wide by 10-foot-deep booth. The front and both sides of the end-cap booth are exposed to aisles. A 10-foot-wide by 8-foot-high back drape is centered in the back of the booth. There are no side drapes.

Use of Space in an End-Cap Booth

The maximum height of the back 5 feet of the booth is 8 feet high.

The maximum height of the front 5 feet of the booth is 4 feet high. All booth materials and displays must be contained within the lines of the booth. Hanging signs, graphics, canopies and other materials from the ceiling is not allowed for this booth type. Diagrams showing layout (including measurements) for end-cap booths are mandatory and must be submitted to SW Expo for approval no later than 60 calendar days prior to setup day for the show.

TOP VIEW

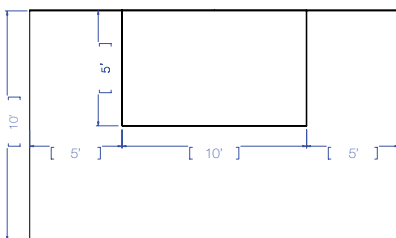

FRONT VIEW

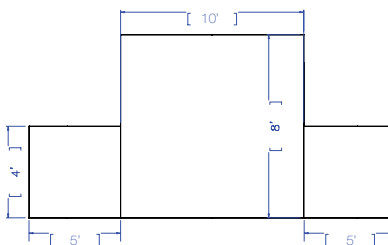

ISLAND BOOTHS

MAIN VIEW

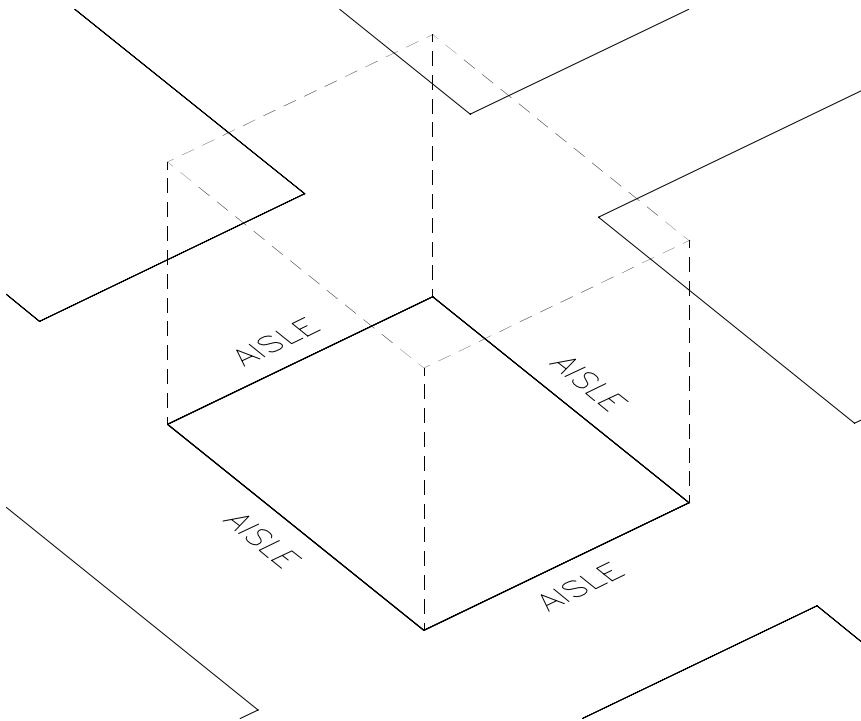

TOP VIEW

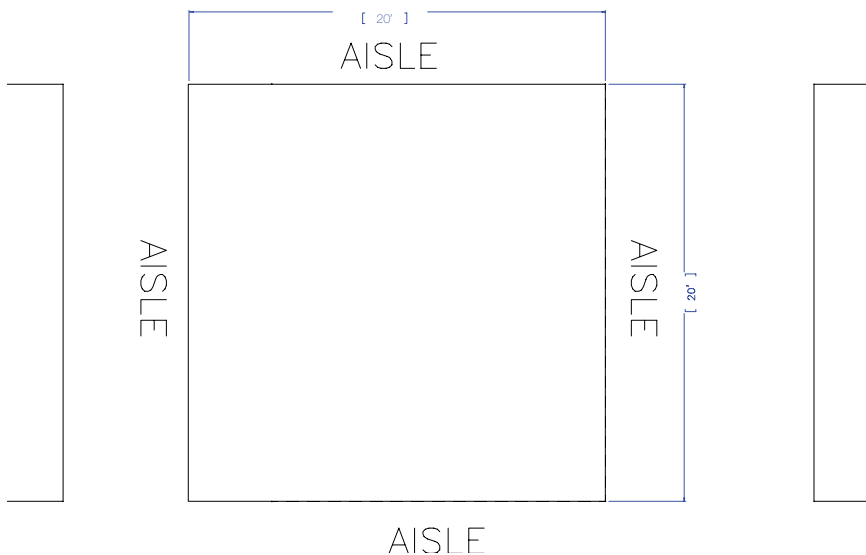

ISLAND BOOTHS

has aisles on all four sides and consists of any number of single 10-foot-deep by 10-foot-wide booths. Drapery is typically not provided for this booth type.

Use of Space in an Island Booth

All booth materials and displays must be contained within the lines of the booth. Hanging signs, graphics, canopies and other materials from the ceiling is allowed for this booth type if allowed by the venue hosting the event. The height restriction is the maximum height allowed at the venue being used for the event. Check the show Exhibitor & Sponsor Prospectus for height restrictions. Diagrams showing layout and any ceiling fixtures (including measurements) for island booths are mandatory and must be submitted to SW Expo for approval no later than 60 calendar days prior to setup day for the show.